

• General Description

The ZM098N06S combines advanced trench MOSFET technology with a low resistance package to provide extremely low $R_{DS(ON)}$.

• Features

- Advance high cell density Trench technology
- Low $R_{DS(ON)}$ to minimize conductive loss
- Low Gate Charge for fast switching
- Low Thermal resistance

• Application

- Synchronous Rectification in DC/DC and AC/DC Converters
- Industrial and Motor Drive applications

• Product Summary

$V_{DS} = 60V$

$R_{DS(ON)} = 10.8m\Omega$

$I_D = 11A$

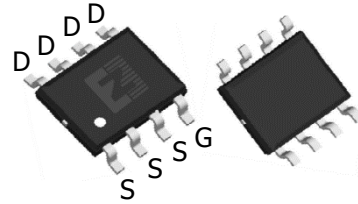

SOP-8

• Ordering Information:

Part NO.	ZM098N06S
Marking	ZM098N06
Packing Information	REEL TAPE
Basic ordering unit (pcs)	4000

• Absolute Maximum Ratings ($T_C = 25^\circ C$)

Parameter	Symbol	Rating	Unit
Drain-Source Voltage	V_{DS}	60	V
Gate-Source Voltage	V_{GS}	± 20	V
Continuous Drain Current ^②	$I_{D@TC=25^\circ C}$	11	A
	$I_{D@TC=75^\circ C}$	8.4	A
	$I_{D@TC=100^\circ C}$	6.9	A
Pulsed Drain Current ^①	I_{DM}	44	A
Total Power Dissipation ^②	$P_D@TC=25^\circ C$	3.6	W
Total Power Dissipation	$P_D@TA=25^\circ C$	0.69	W
Operating Junction Temperature	T_J	-55 to 150	$^\circ C$
Storage Temperature	T_{STG}	-55 to 150	$^\circ C$
Single Pulse Avalanche Energy@L=0.1mH	E_{AS}	80	mJ
Avalanche Current@L=0.1mH	I_{AS}	40	A

•Thermal resistance

Parameter	Symbol	Min.	Typ.	Max.	Unit
Thermal resistance, junction - case ^②	R _{thJC}	-	-	34	° C/W
Thermal resistance, junction - ambient	R _{thJA}	-	-	180	° C/W
Soldering temperature, wavesoldering for 10s	T _{sold}	-	-	265	° C

•Electronic Characteristics

Parameter	Symbol	Condition	Min.	Typ	Max.	Unit
Drain-Source Breakdown Voltage	BV _{DSS}	V _{GS} =0V, I _D =250uA	60			V
Gate Threshold Voltage	V _{GS(TH)}	V _{GS} =V _{DS} , I _D =250uA	1.2		2.5	V
Drain-Source Leakage Current	I _{DSS}	V _{DS} =60V, V _{GS} =0V			1.0	uA
Gate- Source Leakage Current	I _{GSS}	V _{GS} =±20V ,V _{DS} =0V			±100	nA
Static Drain-source On Resistance	R _{DS(ON)}	V _{GS} =10V, I _D =10A		10.8	13.5	mΩ
		V _{GS} =4.5V, I _D =8A		13	17	mΩ
Forward Transconductance	g _{FS}	V _{DS} =25V, I _D =10A		24		s
Source-drain voltage	V _{SD}	I _S =10A			1.28	V

•Electronic Characteristics

Parameter	Symbol	Condition	Min.	Typ	Max.	Unit
Input capacitance	C _{iss}	V _{GS} =0V, V _{DS} =25V f = 1MHz	-	3220	-	pF
Output capacitance	C _{oss}		-	149	-	
Reverse transfer capacitance	C _{rss}		-	106	-	

•Gate Charge characteristics(Ta=25°C)

Parameter	Symbol	Condition	Min.	Typ	Max.	Unit
Total gate charge	Q _g	V _{DD} =30V	-	30	-	nC
Gate - Source charge	Q _{gs}	I _D = 10A	-	9	-	
Gate - Drain charge	Q _{gd}	V _{GS} = 10V	-	6	-	

Note: ① Pulse Test : Pulse width ≤ 300μs, Duty cycle ≤ 2% ;

② Device mounted on FR-4 substrate PC board, 2oz copper, with thermal bias to bottom layer 1inch square copper plate;

Fig.1 Gate-Charge Characteristics

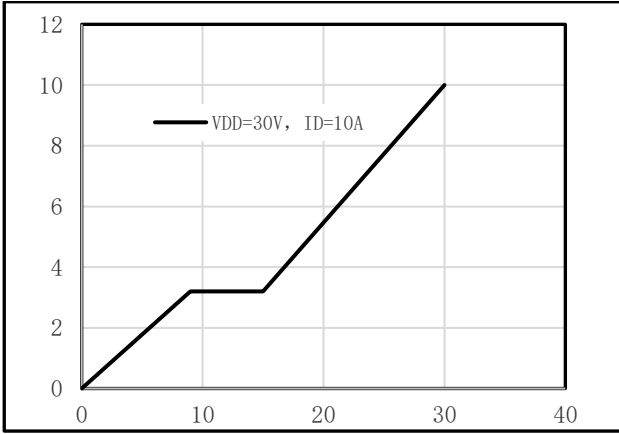

Fig.2 Capacitance Characteristics

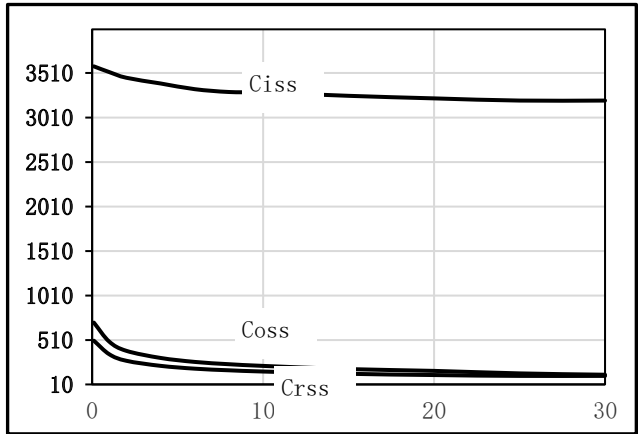

Fig.3 Power Dissipation

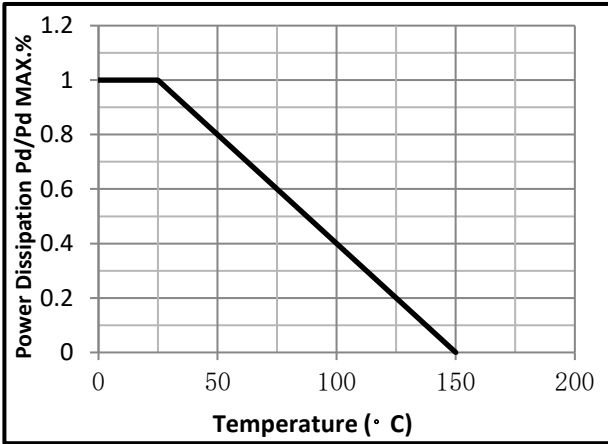

Fig.4 Typical output Characteristics

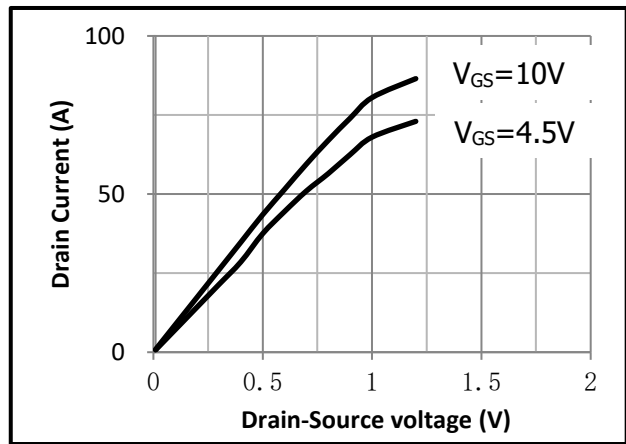

Fig.5 Threshold Voltage V.S Junction Temperature

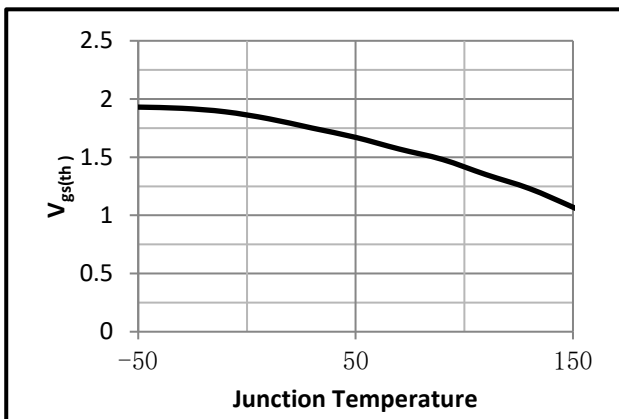

Fig.6 Resistance V.S Drain Current

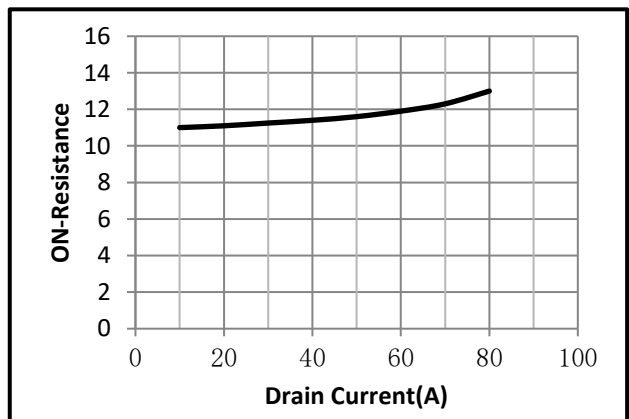

Fig.7 On-Resistance VS Gate Source Voltage

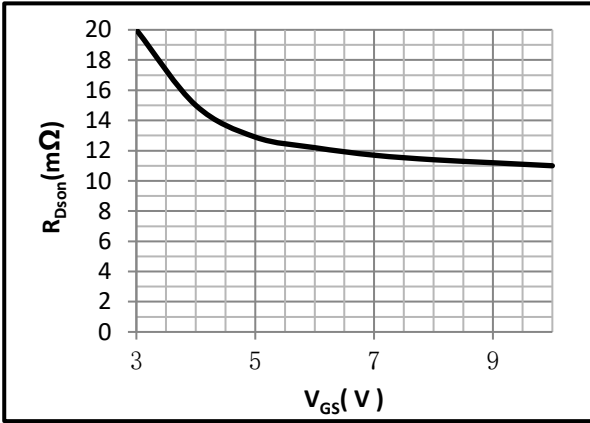

Fig.8 On-Resistance V.S Junction Temperature

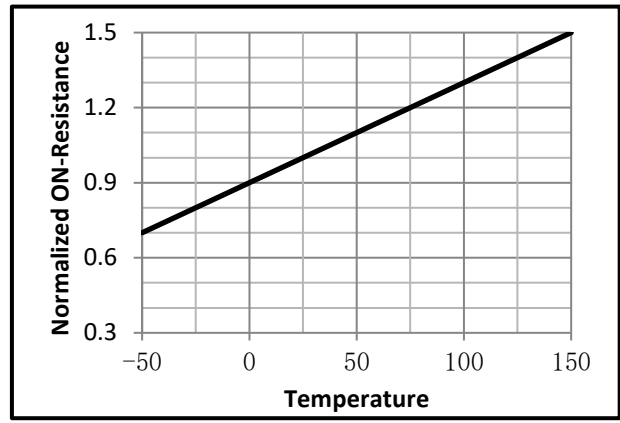

Fig.9 Switching Time Measurement Circuit

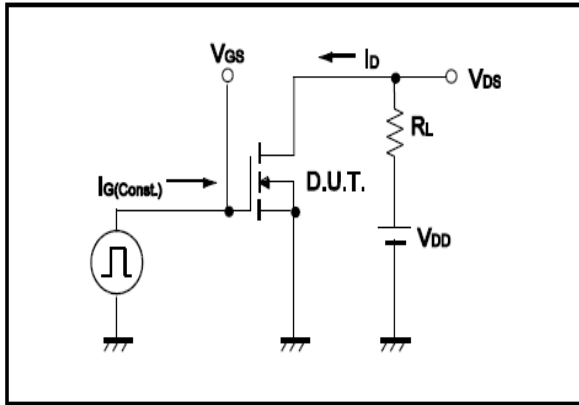

Fig.10 Gate Charge Waveform

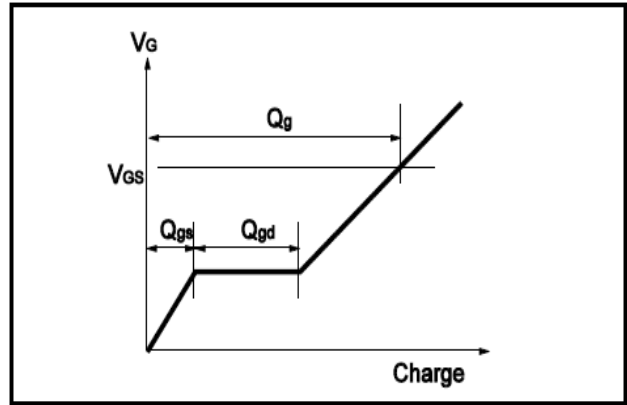

Fig.11 Switching Time Measurement Circuit

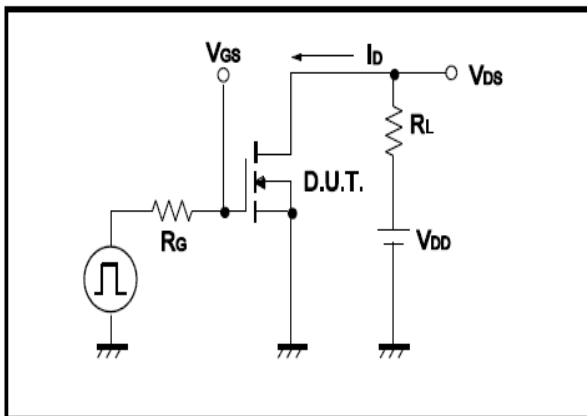

Fig.12 Gate Charge Waveform

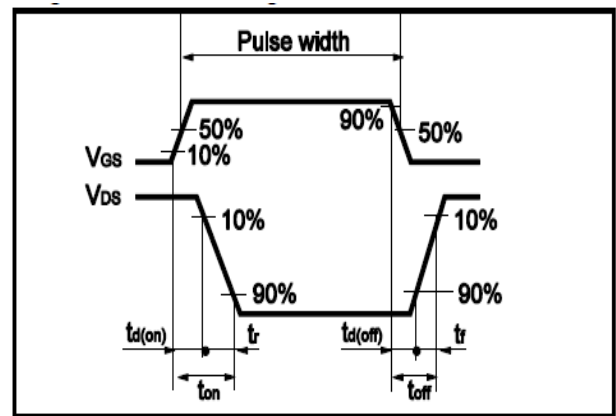

Fig.13 Avalanche Measurement Circuit

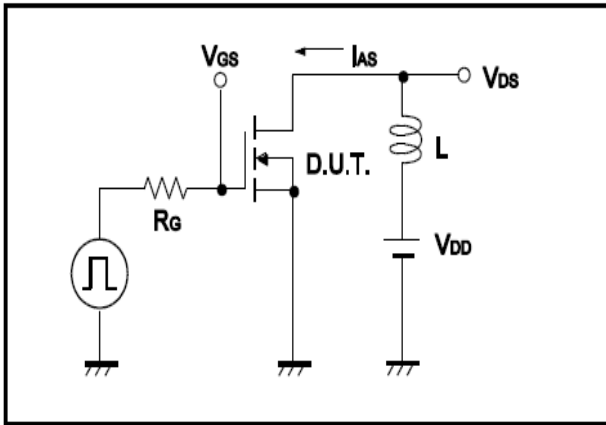
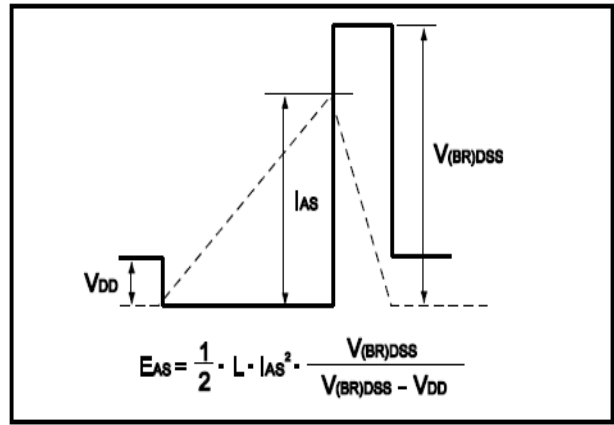

Fig.14 Avalanche Waveform



•Dimensions(SOP8)

Unit: mm

SYMBOL	min	TYP	max	SYMBOL	min		max
A	4.80		5.00	C	1.30		1.50
A1	0.37		0.47	C1	0.55		0.75
A2		1.27		C2	0.55		0.65
A3		0.41		C3	0.05		0.20
B	5.80		6.20	C4	0.19	0.20	0.23
B1	3.80		4.00	D		1.05	
B2		5.00		D1	0.40		0.62

